

Remove all items from the carton . Verify all pieces before assembly.

PART LIST

KEY	QTY	DESCRIPTION	KEY	QTY	DESCRIPTION	KEY	QTY	DESCRIPTION
1	5	Caster	7	1	Backrest	12	2	Arm Bracket
2	1	Base	8	1	Backrest Post	13	2	Armrest
3	1	Seat Post	9	1	Backrest Screw	14	2	Arm Width Adjustment Knob + Washers
4	1	Seat Post Cover	10	1	M5 Size Allen Wrench			
5	1	Mechanism	11	1	Backrest Depth Adj. Knob + Washers (larger)			
6	1	Seat						

STEP 1.

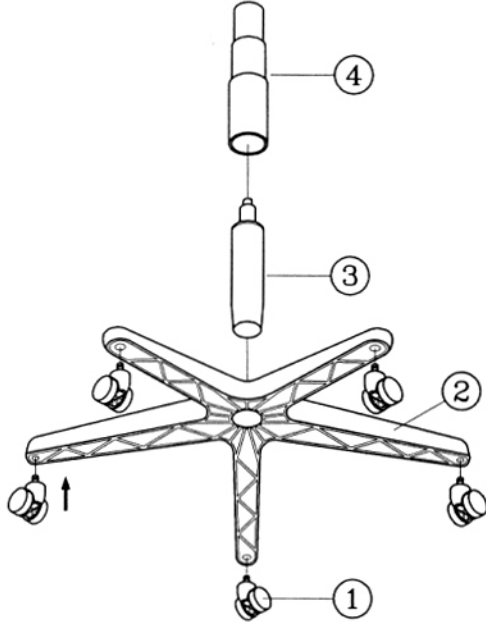

STEP 2.

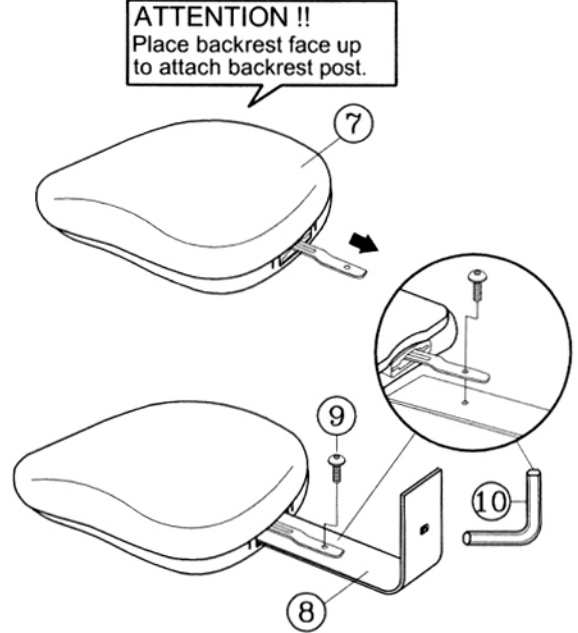

STEP 3.

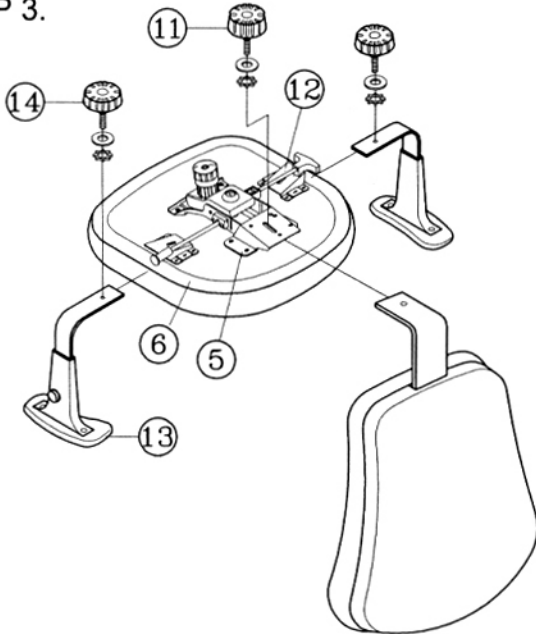

PREVENTIVE MAINTENANCE AND WARNING!

- USE THIS PRODUCT ONLY FOR SEATING ONE PERSON AT A TIME.
- DO NOT USE THIS CHAIR AS A STEP STOOL / LADDER.
- DO NOT SIT ON ANY PART OF THE CHAIR EXCEPT THE SEAT.
- DO NOT USE CHAIR ON UNEVEN FLOOR SURFACES.
- DO NOT USE CHAIR UNLESS ALL BOLTS, SCREWS AND KNOBS ARE TIGHT. AT LEAST EVERY SIX MONTHS, CHECK ALL BOLTS, SCREWS AND KNOBS TO BE SURE THEY ARE TIGHT.
- IF ANY PARTS ARE MISSING, BROKEN, DAMAGED OR WORN, STOP USE OF THE PRODUCT UNTIL REPAIRS ARE MADE USING FACTORY AUTHORIZED PARTS.
- DISPOSE OF PACKAGING PROPERLY. PLASTIC BAG IS NOT A TOY. DO NOT USE PLASTIC BAG AS HEAD COVERING - IT MAY CAUSE SUFFOCATION.
- FAILURE TO FOLLOW THESE WARNINGS COULD RESULT IN SERIOUS INJURY.